

# Axialkolben-Doppelpumpe

HP2D12, HP2D14, HP2D18

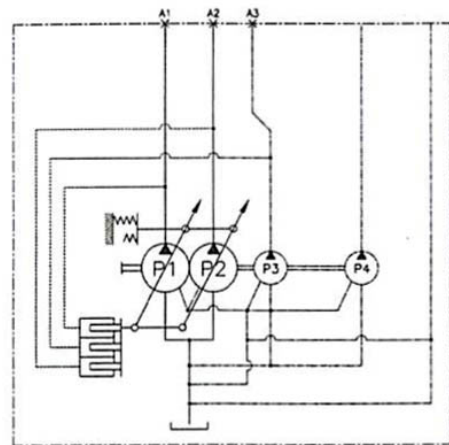
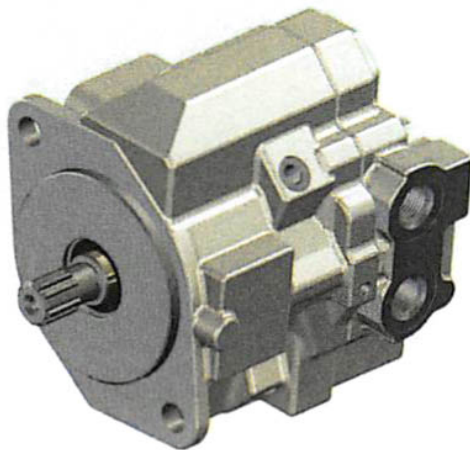

## Spezifikationen

Model	Fördermenge (cm <sup>3</sup> /U)	Max. Druck (bar)	Max. Drehzahl (U/min)
HP2D12	12	245	2800
HP2D14	14		2600
HP2D18	18		

## Masse Wellenende

Model	Anzahl Zähne	∅ Aussen (mm)	Modul	Eingriffswinkel	Standard
HP2D12/14/18	13	20.64	16/32	30°	SAE J498B

## Ansaugflansch

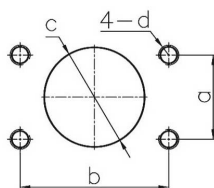

	mm
a	35.7
b	69.9
c	∅ 40
d	M12X1.75P DP18

Masse (mm)

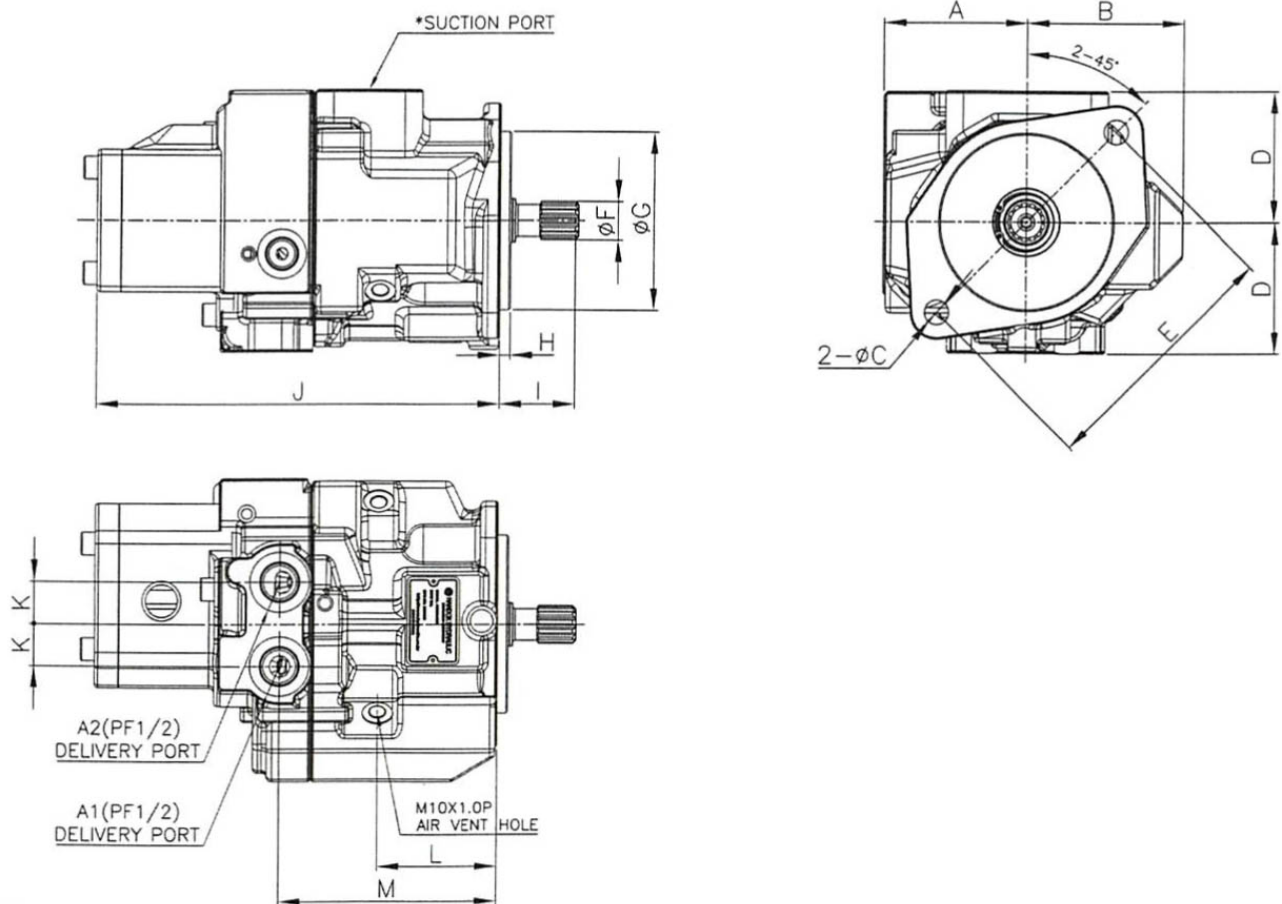

Model	Zähne	A	B	C	D	E	F	G	H	I	J	K	L	M
HP2D12	13	83	90	14	75	146	21.7	101.6	6	43	231.5	24	68.5	125.6
HP2D14/18		91.8	101		90				5	49.2	256	25	75	154